

KNIFE CUTTER PARTS

*Proven Designs,
Dependable Equipment*

PARTS DIAGRAM

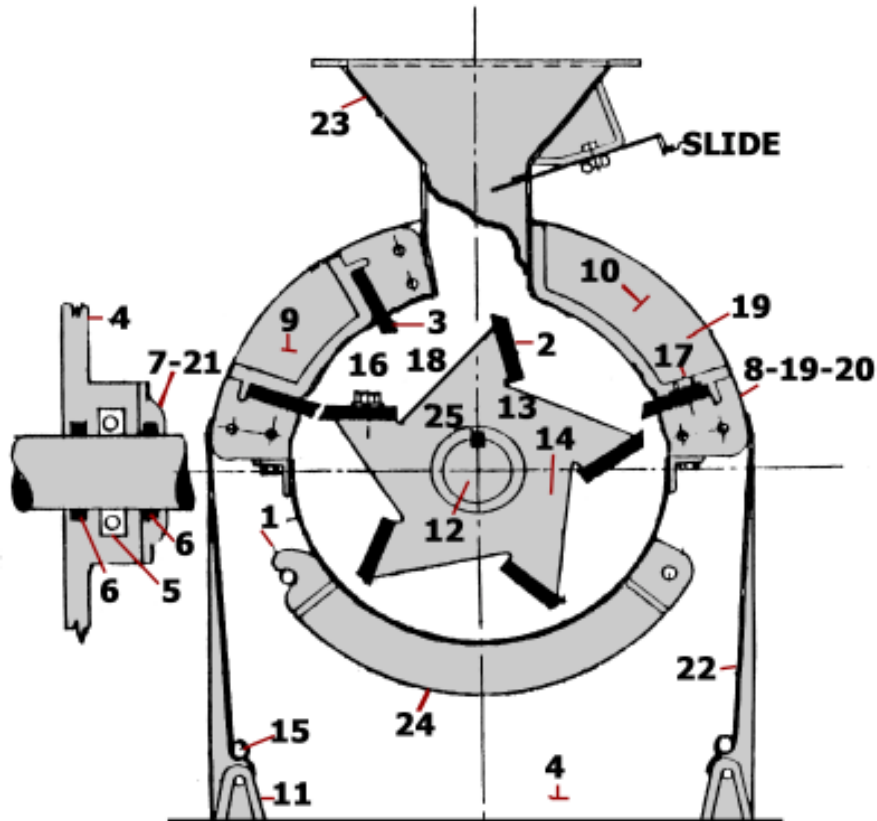

Knife Cutter part numbers are specific to each of our five models. Use this diagram to identify the part and provide us with your Knife Cutter's model, machine or shop order number and a S. Howes sales representative can identify the specifications of the part. We keep numerous parts in stock and can replace any part on our Knife Cutters. Call us for a quote!

<u>Item</u>	<u>Description</u>	<u>Item</u>	<u>Description</u>
1	Cage Screen	14	9" Rotor Head
2	Rotor Knives	15	5/8" Dia. X 26" Ig. Rod with nuts
3	Bed Knives	16	5/8-11 X 1-1/2" Ig. Rotor Knife Bolts
4	End Plates (Heads)	17	1/2-13 X 1/4" Ig. Bed Knife Bolts
5	Flanged Bearings	18	5/8" Lock Washers
6	3/8" Sq. Teflon Packing	19	1/2" Lock Washers
7	End Plate Cap	20	1/2"-13 X 1-1/2" Knife Block Bolts
8	Knife Blocks	21	1/2" - 13 X 1-1/4" Bearing Cap Bolts
9	Narrow Filler Block	22	14 Ga. Mild Steel Doors
10	Wide Filler Block	23	10 X 21 Inlet Hopper with Slide Gate
11	Base Filler Block	24	Steel Welded Cradle
12	Rotor Shaft	25	5/8 X 5/8 X 20" long Key
13	12" Rotor Head		

S. HOWES
Established 1856

Member  PROCESS EQUIPMENT
MANUFACTURERS' ASSOCIATION

Phone: (716) 934-2611
Toll Free: (888) 255-2611
Fax: (716) 934-2081
sales@showes.com

S. Howes, Inc.
25 Howard St.
Silver Creek, NY 14136
www.showes.com