

Bag Dump Station

Two **NEW** models provide for a clean, economical, dust controlled environment. S. Howes Bag Dump Stations enable users to break bags of powdered materials into downstream equipment for further processing while containing dust through jet pulse filter cleaning system.

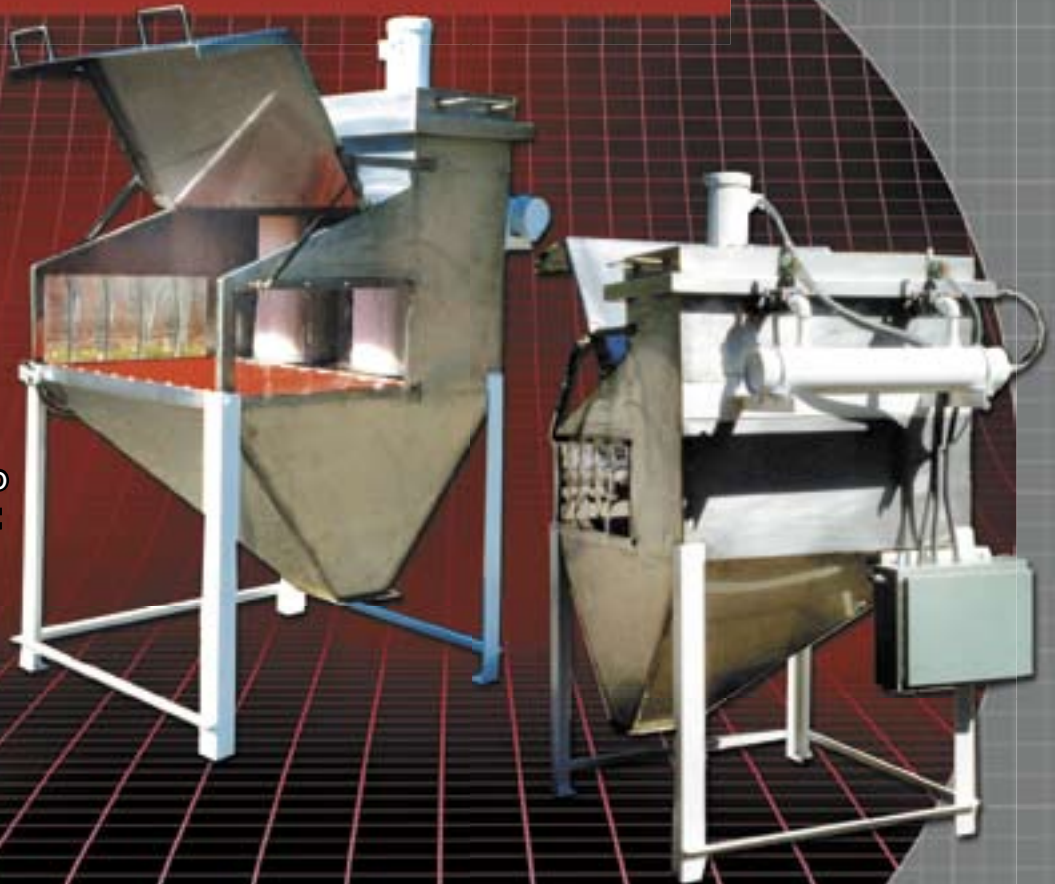

Bag Dump Station on Top of Mixer

Stand Alone Bag Dump Station



For more information
contact one of our Sales Engineers
sales@showes.com
showes.com

S. Howes, Inc.
Phone: (716) 934-2611
Toll Free: (888) 255-2611
Fax: (716) 934-2081
© 2005 S. Howes, Inc., All rights reserved.

Bag Dump Station

Both models feature twin cartridges with jet pulse filter cleaning:

- Available in mild or stainless steel
- Twin cartridge type filters
- Air pulse cleaning when the covers are closed
- Heavy duty construction
- Manual or electronic pulse
- 1 1/2 H.P. blower motor
- NEMA 12 Control Package

Model #12

Can be coupled with a S. Howes screw conveyor of various capacities and lengths.

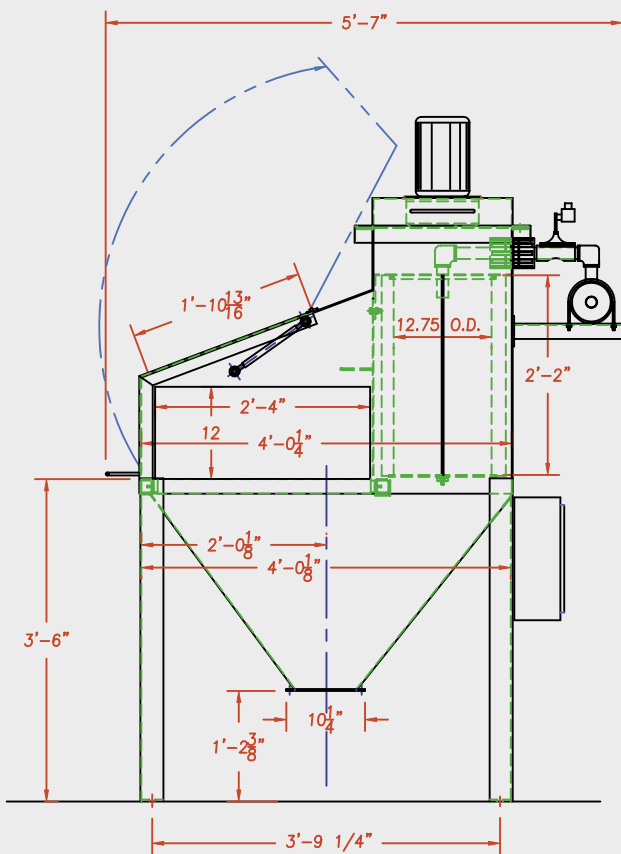

Model #19

Designed to fit existing 5 1/2 cu. foot hoppers. This model will fit on most mixers as an economical dump station.

