



S. HOWES

Snappy Air Finisher

Sample Applications:

- Cereal
- Spices
- Animal Feed
- Potatoes
- Nuts
- Bark
- Corn
- Pepper
- Wood Chips
- Plastics
- Vegetables
- Oat Groups
- Feed
- Grain
- Seed
- Rice Hulls
- Pellets



Authentic S. Howes Ball Screens Perforated for Your Screening Needs

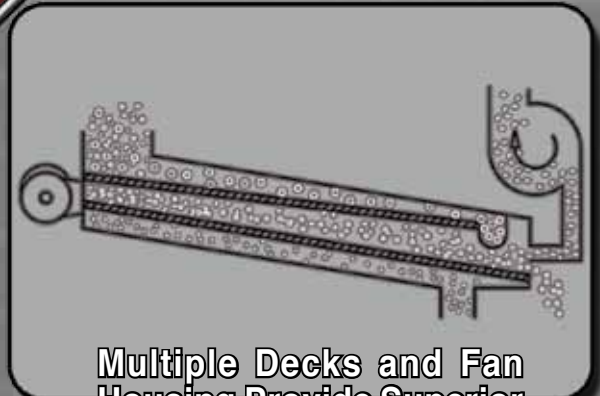
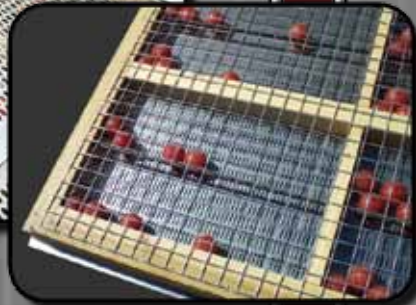
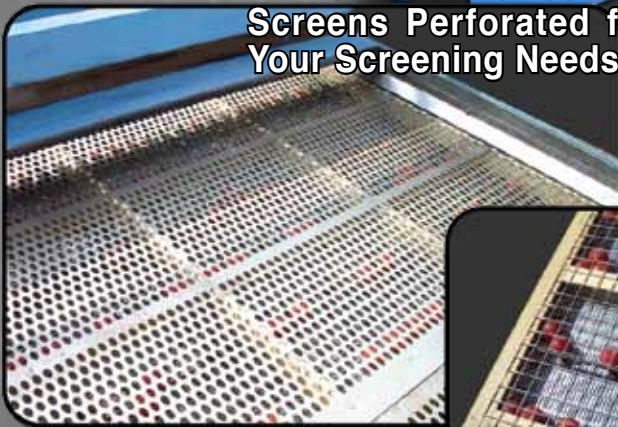

Multiple Decks and Fan Housing Provide Superior Product Separation

For more information contact one of our Sales Engineers
sales@showes.com
www.showes.com

S. Howes, Inc.
Phone: (716) 934-2611
Toll Free: (888) 255-2611
Fax: (716) 934-2081

© 2014 S. Howes, Inc. All rights reserved

Snappy Air Finisher

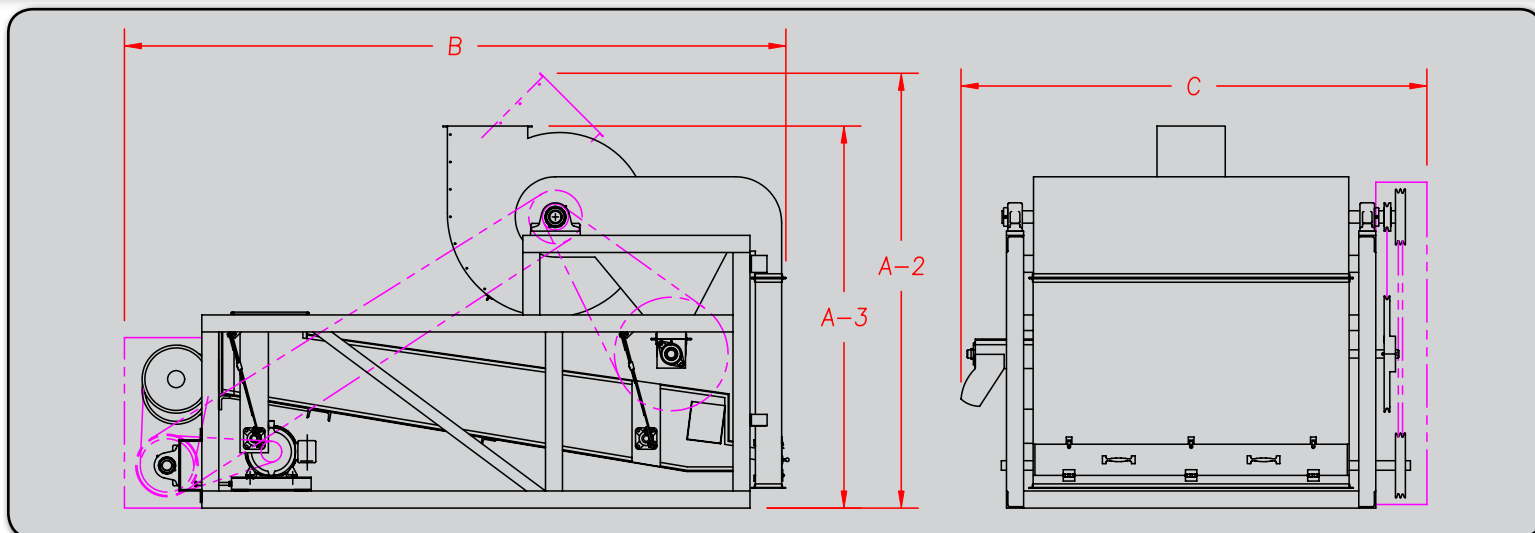

Snappy Air Finisher Specifications*

Air-Finisher Model	1	2	3	4	5	6	7	8	9
A-2 (Fan Position 2)	73	73	73	73	75	75	75	75	75
A-3 (Fan Position 3)	64	64	64	64	66 1/2	66 1/2	66 1/2	66 1/2	66 1/2
B	100	100	100	100	116	116	116	116	116
C	48	54	60	66	76	82	88	94	100
Screen Width	24	30	36	42	48	54	60	66	72
Screen Length	60	60	60	60	72	72	72	72	72
Approx. Shipping Weight (lbs)	1350	1375	1400	1500	1600	1700	1800	1900	2050
Throughput Capacity (tons/hr)*	1-2	2-4	3-5	4-6	8-16	9-18	10-20	11-22	12-24

* Capacities are based on an average of common products. Actual capacities vary because they are dependent on the characteristics of the product as well as screen perforation size and shape. All Dimensions are inches.

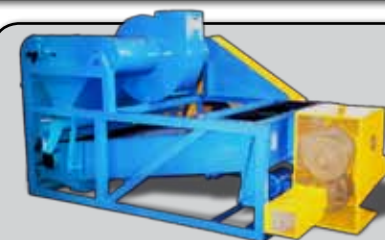

Snappy Air finishers are used for high-intensity screening, cleaning and/or sifting – and are enhanced by aspiration. Nine models are available with single, double or triple deck configurations. Screening capacities range up to 24 tons per hour and 3,200 CFM.

Authentic Metal & Ball Screen Frames Available

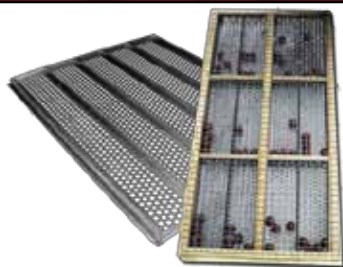

The constant ball agitation aids particle stratification and prevents screen blinding for more efficient cleaning, even when used with materials which tend to clog easily. Metal frames provide for a durable, long lasting life.

Barbeau Drive Provides Years of Reliable Operation



The heart of the Air Finisher is our **Barbeau oscillating, eccentricless drive** which controls vigorous, yet smooth screen action that maintains production efficiency.

Features & Benefits

- High Quality & Heavy-Duty Construction
- Superior Cleaning at an Economical Price
- Lower Power Consumption
- Single Suction Aspiration
- Superior screening capabilities – enhanced by aspiration of light weight materials and dust.
- Low maintenance, low horsepower.
- Easily removable screens.
- Ball screen option aids particle stratification for more efficient cleaning.
- Custom perforations or wire mesh screens available.
- High-quality and heavy-duty construction.
- Available in open, covered or totally-enclosed models for use outdoors or in dust-free environments.

S. Howes, Inc.
25 Howard St.
Silver Creek, NY 14136
showes.com

Phone: (716) 934-2611
Toll Free: (888) 255-2611
Fax: (716) 934-2081
sales@showes.com

