



# S. HOWES

## Centrifugal Sifter

### Sample Applications:

Flour  
Sugar  
Coffee  
Dry Milk  
Casein  
Soya Flour  
Clay  
Talcum  
Carbon  
Resin  
Cereal  
Cement  
Dewatering



**Numerous Screen Options**



**Durable Wedgewire for Abrasive Material**

For more information  
contact one of our Sales Engineers  
[sales@showes.com](mailto:sales@showes.com)  
[www.showes.com](http://www.showes.com)

- Easy cleaning and maintenance
- In-line or stand alone
- Stainless or mild steel construction
- Quick screen change
- Adjustable paddles
- Low RPM, minimal vibrations

S. Howes, Inc.  
Phone: (716) 934-2611  
Toll Free: (888) 255-2611  
Fax: (716) 934-2081

© 2014 S. Howes, Inc. All rights reserved

# Centrifugal Sifter



## JOB ENGINEERED

S. Howes' sales and engineering personnel can recommend a standard design for your application or work with you to develop a custom design, depending on your unique needs. If the features you need are not listed, call to see how we can develop a solution to meet your requirements.

## Standard Features for Centrifugal Sifters

- Heavy duty construction
- Sifters can process virtually any dry products and slurries
- 5 Standard models available to capacities up to 100,00 lbs/hr
- Low horsepower requirements
- Low RPM, few moving parts
- Screen cage is fully removable for screen change and cleaning

## Optional Features for Centrifugal Sifters

Screen Options	Screen Options	Drives	Drives
	<ul style="list-style-type: none"> <li>• Screen Sizes from 5000 Microns (4.3 Mesh), to 150 Microns (100 Mesh)</li> <li>• Metal, Polyester or Nylon Mesh</li> <li>• Durable Wedgewire for Abrasive Materials</li> </ul>		<ul style="list-style-type: none"> <li>• Variable Speed Drives</li> <li>• TEFC Motor</li> <li>• Explosion Proof Motor</li> <li>• Hostile Environment Motor</li> </ul>
	<h3>Access</h3> <ul style="list-style-type: none"> <li>• Viewing Windows</li> <li>• Cleanout Doors</li> <li>• Access Ports</li> <li>• Sanitary Clamp Fittings</li> </ul>		

## Sifter Specifications\*

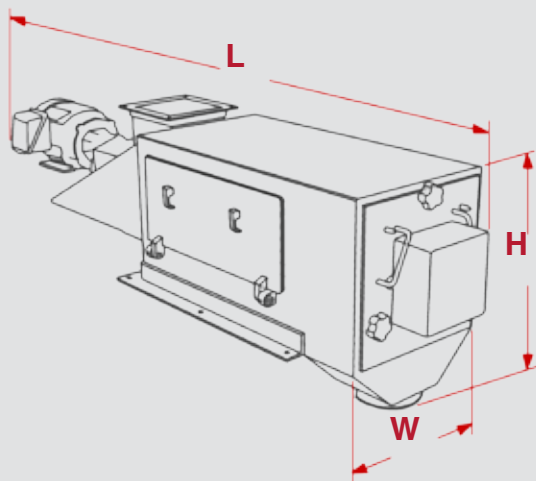

Model	Length "L" (in.)	Height "H" (in.)	Width "W" (in.)	Weight (lbs.)
P/7X11	55	25	16	199
P/7x22	66	25	16	258
P/11x30	73	38	28	551
P/15x42	94	47	31	849

Note(\*): All dimensions and weights are approximate

## Flow Diagram

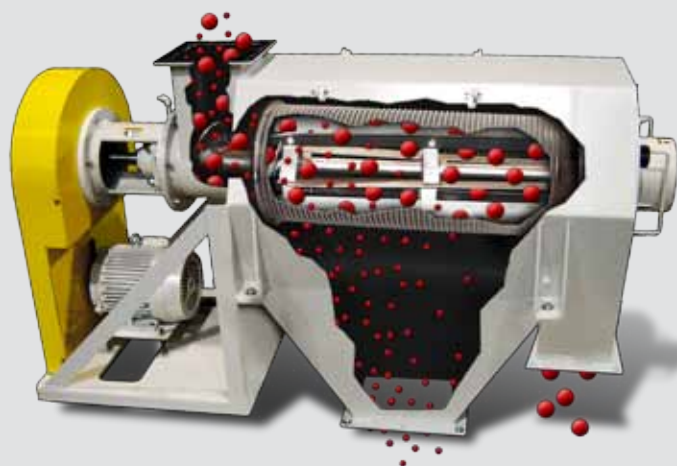

**Method of Operation:** Materials are fed into the sifter inlet and transferred into the sifter chamber by means of a feed screw. The material is then whirled in the sifter chamber by paddles or brushes allowing material to "sift" through the screen for proper sizing.

Oversize materials will exit through the end of the screen chamber for disposal. The screen chamber is available in either open or restricted end design. By design, the paddle assembly does not come in contact with the screens. Vibrations set up by the paddle assembly keep the screen clear and free from binding.

Sifter throughput capacity is dependent on product density, characteristics, and screen size. Contact our sales department for more information or to schedule a product test